

HEAT TRANSFER PROBLEMS FOR THE PRODUCTION OF HYDROGEN FROM GEOHERMAL ENERGY

J. Sigurvinsson^{1*}, C. Mansilla¹, B. Arnason², A. Bontemps^{3,4}, A. Maréchal³, T. I. Sigfusson², F. Werkoff¹

¹CEA/DEN/DM2S/SERMA/LTED CEA/SACLAY (Bat. 470)-91191, GIF-SUR-YVETTE CEDEX FRANCE

* to whom correspondence must be addressed (JS206070@AQUILON.CEA.FR)

²UNIVERSITY OF ICELAND, SCIENCE INSTITUTE, Dunhagi 3,107, REYKJAVIK, ICELAND

³UNIVERSITE JOSEPH FOURIER, BP N°53 38041 GRENOBLE CEDEX 9, FRANCE

⁴CEA/DRT/DTEN/GRETH 11, Rue des Martyrs-38054, GRENOBLE CEDEX 9, FRANCE

ABSTRACT

Electrolysis at low temperature is currently used to produce Hydrogen. From a thermodynamic point of view, it is possible to improve the performance of electrolysis while functioning at high temperature (High Temperature Electrolysis: HTE). That makes it possible to reduce consumption but requires a part of the energy necessary for the dissociation of water to be in the form of thermal energy.

A collaboration between France and Iceland aims at studying and then validating the possibilities of producing hydrogen with HTE coupled with a geothermal source. The influence of the exit temperature on the cost of energy consumption of the drilling well is detailed.

To vaporize the water to the electrolyser, it should be possible to use the same technology currently used in the Icelandic geothermal context for producing electricity by using a steam turbine cycle. For heating the steam up to the temperature needed at the entrance of the electrolyser three kinds of heat exchangers could be used, according to specific temperature intervals.

INTRODUCTION

The use of hydrogen as a substitute to hydrocarbons, is currently the object of many research and development tasks in the world. To be sustainable, a hydrogen production process must be carried out without consumption of raw materials other than water and driven by energy produced

without greenhouse gas emissions. Electrolysis at low temperature carried out using sustainably produced electricity satisfies these constraints and is currently used to produce Hydrogen. However, today it is more expensive than the process of producing hydrogen by steam reforming of natural gas, which presents a double disadvantage since it consumes natural gas and rejects carbon dioxide. From a thermodynamic point of view, it is possible to improve the performance of electrolysis while functioning at high temperature (HTE). That makes it possible to reduce consumption but requires a part of the energy necessary for the dissociation of water to be in the form of thermal energy.

Recent HTE research programs have profited from new financings, mainly within the Generation IV International Forum framework for developing long term nuclear reactors (Generation IV, 2002) . The forum considers the possibilities of using nuclear energy, particularly high temperature helium cooled reactors (HTR) which include the possibility of producing hydrogen.

A collaboration between France and Iceland aims at studying and then validating the possibilities of producing hydrogen with HTE coupled with a geothermal source. Its principal objective is the production of hydrogen by HTE coupled with a geothermal source in the Icelandic context. The goal is to build a 5 kWe prototype on the site of Nesjavellir, which is 20 km from Reykjavik (GEYSER, 2004). Iceland brings its competences and its experience in the field of geothermal drilling, the exploitation, the transport and the transformation (in particular in electric power) of steam extracted at

the geothermal sources. France brings its scientific knowledge and its industrial experience on the thermal problems of heat transfers for various ranges of temperatures, as well as the results of the research and development on Solid Oxide Fuel Cells, which works in reverse of the electrolyzers at high temperature.

Hydrogen from geothermal energy. The economically harnessable geothermal energy in Iceland has been estimated at approximately 200 TWh/year, of which only 1% has been harnessed up to now. Assuming the same technology used in Iceland today to produce electricity from geothermal steam, the 200 TWh/year could be used for the production of 20 TWh/year of electricity, or 17 TWh/year of hydrogen. (Arnason and Sigfusson, 2000)

The Jules Verne Project. The Jules Verne project which was the subject of a convention on behalf of the two states, marks the first stage of the collaboration between France and Iceland. Its principal objective is a techno-economic study of the production of hydrogen by HTE coupled with a geothermal source in Iceland. The estimated duration of the project is from 2003 to 2005. The following stage of collaboration will carry on into a start up program, GEYSER, dated around 2009 to build a 5 kWe prototype on the site of Nesjavellir.

In section 2, we will present the present status of the Nesjavellir plant, and the present heat exchangers used there. Section 3 will be devoted to a discussion on the influence of the heat source temperature (HTR or geothermic) and the presentation of the prospects of deeper drilling. In section 4 requirements for the heat exchanger network for HTE will be provided, taking into account the particularities of the GEYSER project.

PRESENT STATUS OF THE NESJAVELLIR PLANT

The geothermal plant in Nesjavellir (fig. 1) currently produces 90 MW of electric energy and 400MW of thermal energy. The thermal energy is used to heat up water through a heat exchanger after which it is distributed for house heating and general hot water consumption. The heat exchanger is a pipe counter current exchanger (fig 2). There is no need for special anti-corrosion techniques because of the low levels of oxygen in the geothermal steam.

Because of high volcanic activity, the strata of rock under Nesjavellir are relatively young. Rock temperature is highest next to volcanic fractures. At sea level, the temperature there is approximately 100 °C. At two kilometres down, it exceeds 350 °C. In Iceland the drilling wells are usually from 1-3 km deep with pressures from 3-7 MPa.



Fig. 1 The Nesjavellir plant

For electricity production in Nesjavellir, steam is extracted at 3 MPa and vaporized to 1.3 MPa at a temperature of about 200°C. Before entering the turbines steam and water are separated, with minerals exiting with the water and incompressible gases 0.4% of the mass, continuing with the steam.

In Iceland, geothermal energy accounts for 39% of the total consumption, oil accounts for 38%, hydro 19% and finally coal 4%. (Arnason and Sigfusson, 2000) This percentage is so large because all house heating and consumer hot water comes from geothermal resources. The two main processes for producing electricity are the hydro and geothermal energy processes. The electricity production capacity of the national electricity company Landsvirkjun in Iceland is over 1200 MW today and will increase by 600 MW when the newest hydro electric power plant at Karahnjúkar will be ready. While most of the electricity is produced by hydro energy, around 10% is produced by geothermal energy.

Hydrogen has been produced largely from alkaline electrolysis in Iceland for over 50 years, mainly for ammonia used in fertilizer production. A novelty in utilisation happened with the introduction of the ECTOS (ECTOS, 2003) project in 2003, where part of the public transport system in Iceland is run on hydrogen. The hydrogen for the ECTOS project is produced by alkaline electrolyzers technology from Norsk Hydro.



Fig. 2 Heating water heat exchanger at Nesjavellir

THE INFLUENCE OF THE TEMPERATURE OF THE HEAT SOURCE

High-temperature electrolysis (HTE) is an alternative to the conventional electrolysis process. Some of the energy required to split the water is provided as heat instead of electricity, thus reducing the overall energy required and improving process efficiency. Because the conversion efficiency of heat to electricity is low compared to using the heat directly, the energy efficiency can be improved by providing the energy to the system in the form of heat rather than electricity.

In Iceland the cost of extracting thermal energy from a geothermal source is only about 10% of the cost of electricity produced.

$$kWh_{(th-geo)} = 0.1 kWh_{(e-geo)} \quad (1)$$

For HTR the expected efficiency of electricity production is 50% hence we can assume that the cost of thermal energy for HTR is 50% of the price of electricity.

$$kWh_{(th-HTR)} = 0.5 kWh_{(e-HTR)} \quad (2)$$

Thermal energy from a geothermal source is very inexpensive compared to thermal energy from a HTR. In the Icelandic context steam could be supplied at 200°C. According to V.K.Jonsson et al. 1992 only 3.8 kWh_(e)/Nm³H₂ is needed with a thermal input of 200°C, compared with about 4.5 kWh_(e)/Nm³H₂ in conventional electrolyzers. Electricity price to industry in Iceland is approximately 0.014 €/kWh compared to 0.0284 €/kWh (DGEMP-DIDEME, 2003) for middle term electricity produced by nuclear reactors in France. When this price difference is taken into account the difference between producing hydrogen by HTE in Iceland and France is evident, regarding only the cost of vaporizing and heating water to the operating temperature of the electrolyser. (fig. 3)

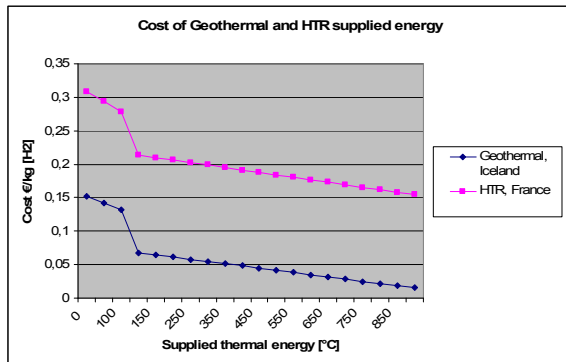

Fig. 3 Cost of vaporizing and heating water to the required temperature for the electrolyser

Table 1 Energy prices, Geothermal/HTR

€/kWh(e) Iceland	0,014
€/kWh(e) France	0,0284
€/kWh(th) Iceland	0,0014
€/kWh(th) France	0,0142

Although only 200°C of thermal input is possible today, that could change. Recent research performed by Landsvirkjun on deep drilling in Iceland show a possibility of extracting 500-600 °C steam at a depth of 4-5 km. At this time deep drilling is purely experimental but could become a possibility within the next 10 years. The influence of the exit temperature on the cost of the energy consumption of the drilling well is obvious.

A recent evolution of the HTR concept is the Very High Temperature Reactor (VHTR) for which the helium temperature at the outlet of the reactor core would be up to 950-1000°C. With this kind of heat source the endothermal solution, discussed in the next section, would be possible with no extra heating by electricity.

THE HEAT EXCHANGER NETWORK

Operating modes for HTE

There are three possible operating modes for HTE depending on the energy balance at the electrolyser level: Endothermal, isothermal and exothermal.

Endothermal. The temperature of the steam decreases from the input of the electrolyser to the output. This corresponds to the best energy efficiency but worst production cost because an endothermal electrolyser is much more expensive than an exothermal one.

Isothermal. The temperature of the steam is the same at the input as at the output. The energy efficiency is better than in the exothermal case but the electrolyser cost still outweighs better efficiency.

Exothermal. The temperature of the steam increases from the input of the electrolyser to the output. This corresponds to the worst energy efficiency but best production cost because an exothermal electrolyser investment cost is the lowest of the three possibilities (T. Pinteaux 2002). The exothermal mode is best suited for the geothermal context since the input temperature is only 200°C.

Heat exchangers

The entering temperature of the electrolyser could be between 750°C and 900°C. To be effective from a thermodynamic point of view, the HTE requires a recovery of the heat contained at the exit from the electrolyser. Heat needs to be recovered in parallel from oxygen and from the hydrogen-steam mixture, in order to heat the steam in contact with the geothermal source, up to the desired temperature at the entry of the electrolyser.

When designing a heat exchanger network for high temperature steam electrolysis, the results should not be the same if the heat source is geothermal or if it is heat produced by a high temperature reactor. This is due to the fact that physical properties are different: the heat is not supplied at the same temperature; and several economic parameters are different too. Indeed, the cost of thermal energy is much lower in the case of geothermal, and the discount rate should not be the same. The high temperature heat exchanger network has been optimised with a techno-economic method using genetic algorithms (Mansilla *et al.*, 2005). The principle of the method is minimizing an objective function: the total cost, which includes investment costs as well as operating costs.

Figure 4 shows the heat exchanger network for an exothermal HTE coupled with an HTR. The heat exchanger network adapted to geothermal heat (fig. 8) will differ from HTR at the thermal source with the addition of more types of exchangers specified for different temperature levels. The heat exchangers can be classified into 3 categories according to the ranges of temperatures

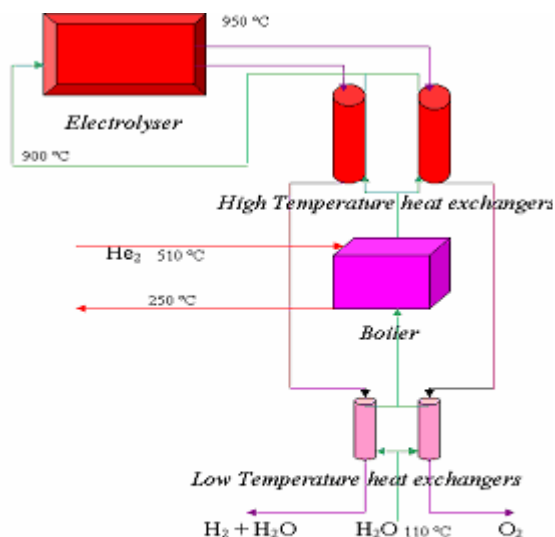

Fig. 4 Exothermal heat exchanger network coupled with an HTR

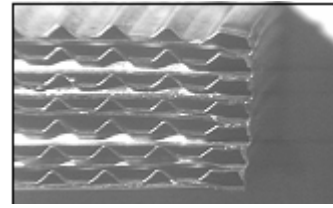

Fig. 5 Medium temperature exchanger

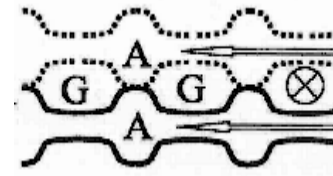

Fig. 6 High temperature exchanger



Fig. 7 Very high temperature exchanger

Since we have a wide range of temperatures, we need different heat exchangers and materials. All of the suggested heat exchangers are counter-current flow and primary surface heat exchangers. The temperature intervals are defined as follows:

Medium temperature: < 650°C, Stainless steel heat exchanger capable of 7 MPa up to 300 °C. (fig. 5).

High temperature: 650°C < T < 850°C, nickel based heat exchanger capable of 1 – 2 MPa at 650 °C, currently under testing. (fig. 6).

Very high temperature: > 850 °C, ceramic based heat exchanger capable of 10 – 50 MPa at 850 °C, more investigation on what material and which heat exchanger to use for this temperature level is needed. (fig. 7)

The heat exchanger suggested for the > 850°C temperature level is still being tested and further detail will be available soon. However it could also be possible to operate the electrolyser at lower than 850°C temperatures using existing technology.

In assuming that plate heat exchangers with primary surfaces are used to insure a high effectiveness, the overall heat transfer coefficient can be derived as follows, neglecting the conduction thermal resistance:

$$U = \frac{1}{\frac{1}{h_1} + \frac{1}{h_2}} \quad (3)$$

where h_1 and h_2 are the heat transfer coefficients for the hot (1) and cold (2) side respectively and given by

$$h_i = \frac{Nu_i \lambda_i}{d_h}, i = 1, 2 \quad (4)$$

where $d_h = 2e$ is the hydraulic diameter and where Nu_i is the Nusselt number which can be calculated for specific plates by (GRETh, 1999)

$$Nu_i = 0.0254 Re_i^{0.638} Pr_i^{1/3} \quad (5)$$

Pr_i being the Prandtl number and Re_i being the Reynolds number calculated from

$$Re_i = \frac{2 \dot{m}_i}{\mu_i B} \quad (6)$$

where B is the plate width, \dot{m}_i the mass flow rate and μ_i the dynamic viscosity of the fluid in the hot ($i=1$) and in the cold ($i=2$) side respectively.

These here above equations allow us to determine U and to calculate either the heat flow rate \dot{Q} or the heat exchange area A using the logarithmic mean temperature difference ΔT_{ml} following the classical equation

$$\dot{Q} = U A \Delta T_{ml} \quad (7)$$

Heat exchanger network

The geothermal heat exchanger network is presented in figure 8. Writing the heat and mass balance equations for each heat exchanger and relating it to their heat transfer rates calculated with the equation (9), the characteristics of the heat exchanger network can be optimised to minimize total cost. In this calculus, a recycling of the gases must be taken into account. The output of the electrolyser is firstly oxygen and secondly a mixture of hydrogen and steam. This mixture is dependent on the recycling ratio r . Not all the water is electrolysed and the number r indicates this ratio of unelectrolysed water. The mixture of water and hydrogen is defined as follows:

$$\dot{m}_{1,H2} = (1-r) \cdot \dot{m}_{H2O} \cdot \frac{M_{H2}}{M_{H2O}} + r \cdot \dot{m}_{H2O} \quad (8)$$

$$\dot{m}_{1,O2} = \frac{(1-r)}{2} \cdot \dot{m}_{H2O} \cdot \frac{M_{O2}}{M_{H2O}} \quad (9)$$

The main characteristics of the heat exchanger network are presented in table 2 and figure 8 when it is optimised to minimize the total cost.

Table 2 Heat exchanger characteristics

\dot{m}_{H2O} (kg/s)	15.4
$\dot{m}_{1,H2}$ (kg/s)	6.2
$\dot{m}_{2,H2}$ (kg/s)	12.1
$\dot{m}_{1,O2}$ (kg/s)	9.2
$\dot{m}_{2,O2}$ (kg/s)	3.3
$Q_{H2,HT}$ (kW)	6049
$Q_{H2,MT}$ (kW)	6323
$Q_{H2,LT}$ (kW)	6895
$Q_{O2,HT}$ (kW)	1587
$Q_{O2,MT}$ (kW)	2193
$Q_{O2,LT}$ (kW)	1404
Q_{total} (kW)	24456
$\epsilon_{H2,HT}$	0.845
$\epsilon_{O2,HT}$	0.841
$\epsilon_{H2,MT}$	0.893
$\epsilon_{O2,MT}$	0.900
$\epsilon_{H2,LT}$	0.897
$\epsilon_{O2,LT}$	0.897
4072 < Re < 23897	
6.36*10 ⁻⁴ < Pr < 9.73*10 ⁻³	
U ~ 1(kW/m ² °C)	

In fig 8 the heat exchangers are labelled as follows: High Temperature (HT), Medium Temperature (MT), Low Temperature (LT).

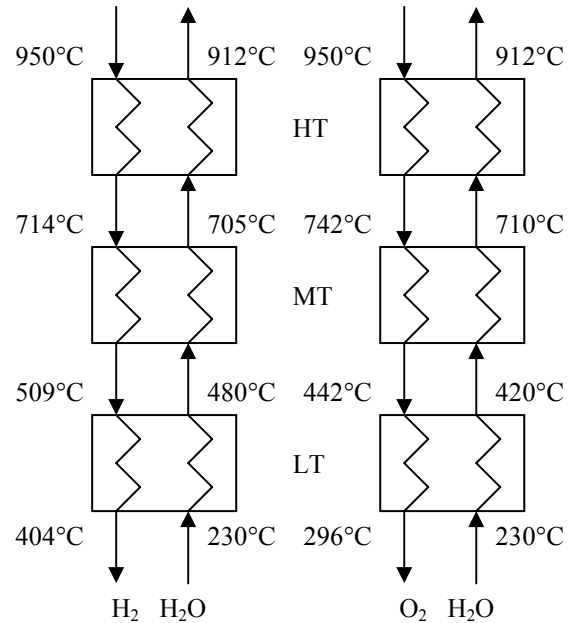

Fig. 8 Geothermal heat exchanger network

CONCLUSION

The production of Hydrogen by High Temperature Electrolysis appears to be very promising mainly in the Icelandic geothermal context. One key to the HTE efficiency is the recuperation of heat at the outlet of the electrolyser by heat exchangers. The needed heat exchangers are under test for medium and low temperatures but over 850°C they still need further developing.

NOMENCLATURE

A :	Heat exchange surface area (m ²)
B :	Width of the plate exchanger (m)
d_h :	Hydraulic diameter (m)
\dot{m} :	Mass flow rate (kg/s)
μ :	Dynamic viscosity (kg/m.s)
k :	Thermal conductivity (W/m.°C)
Pr :	Prandtl number
h :	Heat transfer coefficient (W/m ² .°C)
U :	Overall heat transfer coefficient (W/m ² .°C)
e :	Height of the channel (m)
\dot{Q} :	Power, heat flow rate (kW)
ϵ :	Effectiveness of the heat exchanger
Re :	Reynolds number
Pr :	Prandtl number
M :	Molar mass
r :	Recycling ratio

SUBSCRIPTS

1 :	Steam n°1
2 :	Steam n°2
3 :	Steam n°3
4 :	Steam n°4
HT :	High temperature
MT :	Medium temperature
LT :	Low temperature
H_2 :	Properties of hydrogen
O_2 :	Properties of oxygen
H_2O :	Properties of water

REFERENCES

- Arnason Bragi and Sigfusson T.I., 2000, Iceland as a future Hydrogen Economy, *International Journal for Hydrogen Energy* 25. Pp 389-394.
- Jonsson V., Gudmundsson R.L., Arnason B. and Sigfusson T.I., 1992, *The Feasibility in Using Geothermal Energy in Hydrogen Production, Geothermics, Vol. 21 No 5/6 pp 673-681.*
- ECTOS, <http://www.newenergy.is/ectos.asp>, 2003, *Ecological City Transport System.*
- Mansilla, C., Sigurvinsson J., Bontemps A., Maréchal A., Werkoff F., 2005, Heat management for hydrogen production by high temperature steam

electrolysis *18th International Conference on Efficiency, Cost, Optimization, Simulation and Environmental Impact of Energy Systems*

Pinteaux, T., 2002, Analyse des potentialités de production d'hydrogène par électrolyse de la vapeur d'eau à haute température en couplage avec un réacteur nucléaire de type High Temperature Reactor (HTR). *DRT, Université Joseph Fourier.*

GENERATION IV, 2002, *Generation IV Roadmap Crosscutting Economics R&D Scope Report.* GIF-007-00, December 2002: http://gif.inel.gov/roadmap/pdfs/007_crosscutting_economics_r-d_scope_report.pdf

DGEMP-DIDEME, *Coûts de référence de la production électrique*, 2003.

GEYSER, 2004, High temperature electrolysis at CEA and comparison with other hydrogen production technologies, *IEA Workshop on high temperature electrolyse., San Antonio.*

GRETh, 1999, Pertes de pression et transfert de chaleur dans les échangeurs à plaques en simple phase, *Manuel technique du GRETh.*